



# ***WR-ALC*** ***Requirements*** ***Symposium*** **Technology Insertion**

**Mr. Victor Rozeboom**  
**WRALC/ENSN**  
**19 Nov 2008**



# Overview



- Supported Item Families
- Supported Processes
- The Air Logistics Center Vision
- The User Vision
- Top Technology Needs
- Summary





# WR-ALC Item Families



- Aircraft (C-5, C-130, F-15, C-17, U2, Rot. Wing)
- Hydraulics, pneumatics, wiring, structures
- Avionics, Comm., Nav., Situational Awareness
- Electronic Warfare: Defensive and Jammers
- Ancillary: Support equipment, testers, etc.
- Vehicles: Forklifts, fire engines, loaders, etc.
- Basic Expeditionary Airfield Resources (BEAR)
- Force Protection, Health Protection, CBRNE, munitions





# WR-ALC Processes



- Asset Management – Full product management
  - Supply Chain Management
  - Logistics
- Engineering Control – Engineering authority
  - Operational safety, suitability, and effectiveness
  - Configuration Management
- Maintenance Activities – Complete repair and overhaul
  - Electronics diagnostics, teardown, and rebuild
  - Complete aircraft diagnostics, teardown and rebuild
  - Full shops for electronics, radar, composites, etc.
- Manufacturing Activities – Complete capability
  - Software programming
  - Electronics and structures manufacture

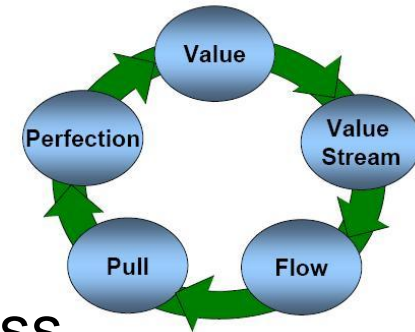



# *The Air Logistics Center Vision*



## ➤ Increased Aircraft Availability

- Reduced Costs
- Enhanced Competitiveness
- Improved Systems / Processes
- Added Core Competencies
- Added Partnerships





# *The User Vision*



- Increased Effectiveness
  - Increased Reliability
  - Reduced Maintenance
  - Improved Safety
  - Enhanced Suitability
  - Enhanced Effectiveness



**Technology Insertion is one avenue to reach our vision!**



# Strategic Technology Sustainment Thrusts



## Top Down Capability Driven Process

### Strategic Drivers

Leads To...

### Strategic Thrusts

#### E-Log21

- Reduced Costs and increase availability

#### AFMC Balance Scorecard

- Improve availability, enhance reliability, reduce cost

#### Customer Needs

- MAJCOMs, AFMC

#### AFRL Focused Long Term Capabilities

- Affordable mission generation & sustainment

#### Agile Combat Support

- Agile, responsive & effective sustainment

- Improve sustainability of weapon systems
- Influence sustainability of new systems
- Improved Inspection, Fault Detection, Diagnostics and Prognostics
- Apply Advanced Practices for complex processes
- Expand alternate energy use
- Reduce impact to the environment

**Top technology needs emphasize strategic drivers**



# WR-ALC Technology Insertion – Top Needs



## ➤ Continuous Condition Monitoring

- Integrated Systems Health Monitoring
- Aircraft Subsystem Diagnostics
- Prognostics based on existing data
- Integrated Structural Health Monitoring
- Prognostic Health Management in Digital Systems



## ➤ Maintenance Acceleration/Increased Density

- Crack and Corrosion Detection and Prevention
- Bonded Repair Technologies
- Supply Chain Enhancements
- Reduced coating-removal times
- NDI Techniques and Technologies



(Slide 1 of 3)



# ***WR-ALC Technology Insertion – Top Needs***



## ➤ Improved Reliability

- Cost Reduction
- Obsolescence Management
- Higher life-cycle components
- Development of special coatings
- Improved High Power Amplifiers
- High-Intensity Discharge for A/C Lighting

## ➤ Improved Agile Combat Support

- Improve BEAR Technologies
- Improve supply chain methods



(Slide 2 of 3)



# ***WR-ALC Technology Insertion – Top Needs***



## ➤ Energy

- Cost efficient and environmentally conscious
- Small, transportable alternative energy sources
- Hybrids, renewable, hydrogen, fuel cells, biofuel, distributive power generation
- Energy conservation

## ➤ Environment

- Reduce impact
- Lead-free solder
- Chrome replacement
- De-paint and coating removal alternatives



**Technology Insertion typically emphasizes partnerships**



# Partnerships



## ➤ Benefits

- Reduced development and operations costs for industry
- Improved technology and capability for Government
- Improved responsiveness to the warfighter

## ➤ WR-ALC partnership efforts

- Use government sponsored development efforts
- Increase maintenance partnerships
- Foster performance based logistics solutions

**Actively seeking other opportunities**



# ***Material Support Division- Engineering***



- Materiel Support Division (MSD) engineering sustaining projects that are budget code 8 (repairable) items that are used to improve the safety, sustainability, and also the reliability of Air Force weapon systems.
- MSD projects are funded by the AF Working Capital Fund (AFWFC).
- Sustaining Engineering projects support discrete engineering efforts of National Stock Numbers, required to resolve technical or supportability deficiencies revealed in operational service. MSD funds are not for the purpose of upgrading.



# Success Stories



## Radar Analog Signal Converter (ASC) Low Voltage Power Supply (LVPS)

- Component obsolescence driving Force Structure Reduction in CY05
- Identified LVPS SRU as ASC reliability driver as well

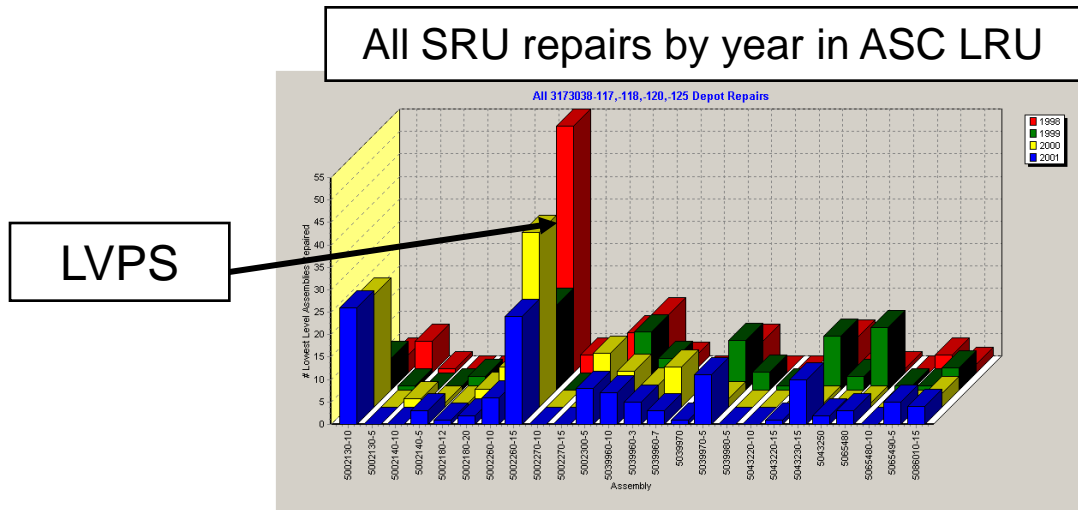

- LVPS redesign put on contract with FY02 MSD funds
- Resolves highest obsolescence and reliability driver



# Success Stories



## AN/AWG-27 Programmable Armament Control Set (PACS)

### H009 Bus Controller SRU

- Component obsolescence and reliability issues
- Redesign solves obsolescence & increases reliability by 500%

Legacy

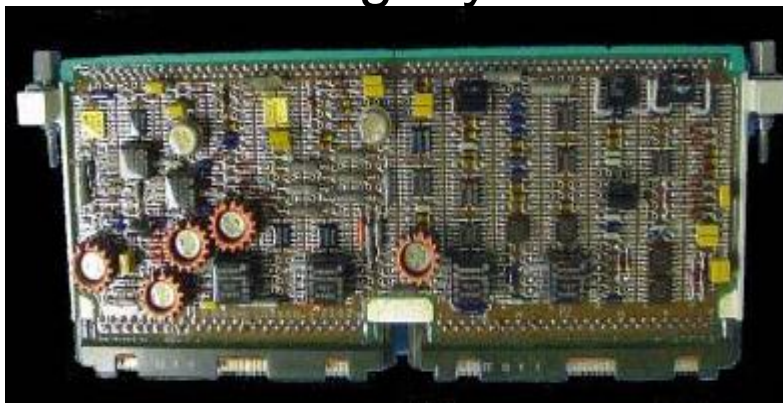

MTBF 8,530hrs

Power Consumption 4.3W

Redesign



MTBF 45,000hrs

Power Consumption 1.8W



# Success Stories



## AN/APG-70 Radar Transmitter

### Power Converter and Control SRU

- Component obsolescence driving force structure reduction
- Redesign solves obsolescence & increases reliability
- New SRU uses existing firmware, saving significant re-host cost

Redesign

Legacy

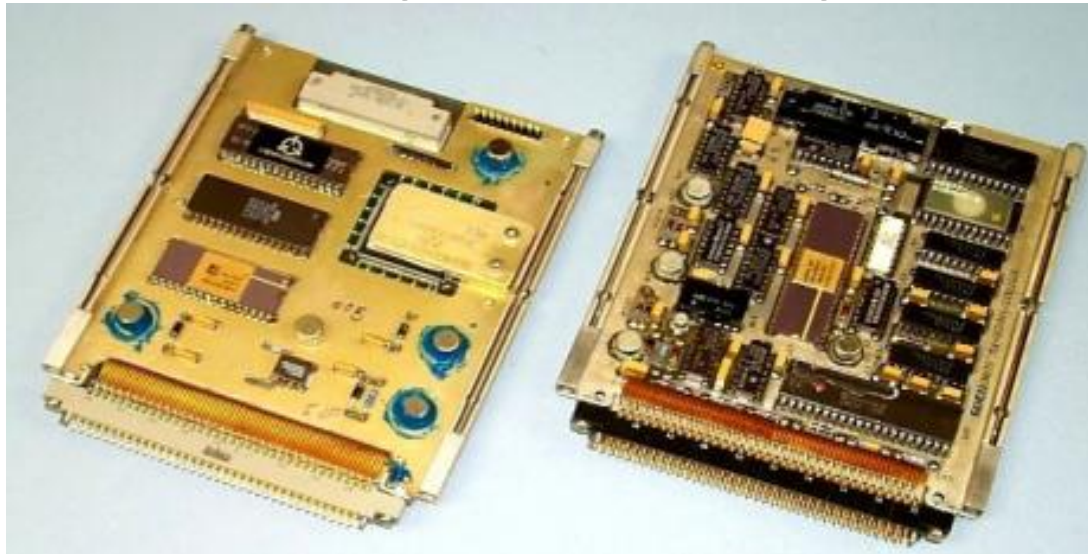



# Success Stories



## WFOV HUD Camera Modification

- Component obsolescence driving Force Structure Reduction
  - CY2000: Sustainment tool predicted aircraft holes in CY2002
  - Original fielding date of June 2002 for new camera slipped right
  - Aircraft holes began in Sep 2002, validating prediction
- Final fielding of new camera in Oct 2002 resolved the problem

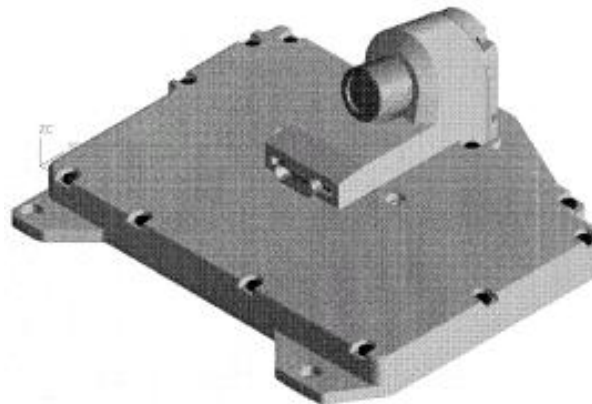





# FY09 MSD PROJECTS

SCM	Project Title
WR-Auto_Test	E-3 BRAT-Phase Noise Measurement Module
WR-Auto_Test	B1-B EASTE POWER SUPPLY
WR-Auto_Test	B1-B EASTE OSCILLOSCOPE
WR-Auto_Test	E-3 BRAT RF Controller
WR-Avionics	3A Reduction of Obsolescence
WR-Avionics	FLIR Aircraft Testing
WR-Avionics	AN/APQ-166 Radar Pressurization Unit Redesign
WR-Avionics	B-52 Turret Drive Assy Redesign
WR-Avionics	WR-ALC Obsolescence Database
WR-Avionics	A-10 HUD PU 3FI Project
WR-Commodities	Re-engineering the 712420-3 MACAWS Panel
WR-Commodities	MAU-40/50 Bomb Rack Extended Maintenance Study
WR-Commodities	RCM Analysis of the 30mm Gun System
WR-Commodities	24 Month Inspection Extension
WR-Commodities	AC-130H Gyro/Synchro/Resolver Improvement Study
WR-Commodities	AC-130H Synchro Resolver Redesign



# FY09 MSD PROJECTS



SCM	Project Title
WR-Elect_Warfare	ALQ-122 Synthesizer, Cntmsrs
WR-Elect_Warfare	ALQ-161_5712_Dual Dielectric Resonator Oscillator Y1
WR-Elect_Warfare	ALQ-161_7499_Band 7 Dual Detector Limiter
WR-Elect_Warfare	ALQ-161_2000_Dual Dielectric Resonator Oscillator Y6
WR-Elect_Warfare	ALQ-161_2001_Dual Dielectric Resonator Oscillator Y7
WR-Elect_Warfare	ALQ-161_2278_RF Amplifier
WR-Elect_Warfare	ALQ-161_8930_Variable RF Attenuator
WR-Elect_Warfare	ALQ-161_8030_Switched RF Modulator
WR-Elect_Warfare	ALQ-161_8101_Switched RF Filter
WR-Elect_Warfare	ALQ-161_7832_FM Combiner Assembly Band 6
WR-Elect_Warfare	ALQ-161_1999_Dual Dielectric Resonator Oscillator Y5
WR-Elect_Warfare	ALQ-184 578R729H03 Redesign
WR-Elect_Warfare	ALQ-161_8102_Switched RF Filter
WR-Elect_Warfare	ALQ-161_1144_FM Combiner Assembly Band 7
WR-Elect_Warfare	ALQ-213 CMSP Detent Switch



# FY09 MSD PROJECTS



SCM	Project Title
WR-Elect_Warfare	ALQ-161_2821_Band 8 Dual detector hybrid limiter high sensitivity
WR-Elect_Warfare	ALQ-161_7925_Dual Dielectric Resonator Oscillator Y9
WR-Elect_Warfare	ALQ-155 HD-766A Liquid Cooler
WR-Elect_Warfare	ALQ-122 Processor, MX-9187
WR-Elect_Warfare	ALQ-122 Control Monitor, C-9040
WR-Elect_Warfare	ALQ-122 Duplexer, CU-2030
WR-Elect_Warfare	ALT-32 RF MODULE ASSEMBLY, HI-BAND
WR-Elect_Warfare	ALT-32 MODULATOR MODULE ASSY, HI-BAND
WR-Elect_Warfare	ALT-32 POWER SUPPLY MODULE ASSY
WR-Elect_Warfare	ALT-32 CONTROL-INDICATOR, HIGH BAND
WR-Elect_Warfare	ALT-32 CONTROL-INDICATOR, LOW BAND
WR-Elect_Warfare	ALT-32 RF MODULE ASSY, LOW BAND
WR-Elect_Warfare	ALT-32 MODULATOR MODULE ASSY, LO-BD
WR-Elect_Warfare	ALT-32 POWER SUPPLY, MODULE ASSY, LB
WR-Elect_Warfare	ALQ-161_2821_Band 8 Dual detector hybrid limiter high sensitivity



# FY09 MSD PROJECTS

SCM	Project Title
WR-Elect_Warfare	ALQ-155 Liquid Cooler Assy
WR-Elect_Warfare	ALQ-155 MX- 8225 Flow Prot. Val.
WR-Elect_Warfare	ALQ-161_8661_Dual Dielectric Resonator Oscillator Y2
WR-Elect_Warfare	ALQ-161_5713_Dual Dielectric Resonator Oscillator Y3
WR-Elect_Warfare	ALQ-161_1998_Dual Dielectric Resonator Oscillator Y4
WR-Elect_Warfare	ALQ-161_2002_Dual Dielectric Resonator Oscillator Y8
WR-Elect_Warfare	ALT-16 POWER SUPPLY ASSEMBLY
WR-Elect_Warfare	ALT-16 CONTROL ASSEMBLY
WR-Elect_Warfare	ALT-16 TRANSMITTER, RADIO
WR-Elect_Warfare	ALR-20 C-9449 Control Box
WR-Elect_Warfare	ALR-20 Tuner (TN-386)
WR-Elect_Warfare	ALR-20 Power Supply PP-3406
WR-Elect_Warfare	ALR-20 Panoramic Indicator
WR-Elect_Warfare	ALT-32 Power Supply
WR-Elect_Warfare	ALQ-135 Control Oscillator Redesign
WR-Elect_Warfare	ALQ-128 Countermeasures Receiver



# MSD PROJECTS

SCM	Project Title
WR-SOF_CSAR	MC-130E Radome Deficiency
WR-SptEquip_Vehicles	Remanufactured Engine Quality Improvement
WR-SptEquip_Vehicles	Reverse Engineer MHU-196/204 Return Filter Cap
WR-SptEquip_Vehicles	Testing to determine wear of contact lenses with MCU-2P
WR-SptEquip_Vehicles	P6AV Hydraulic test stand main pump replacement
WR-SptEquip_Vehicles	4550-0018 Hydraulic test stand main pump replacement