



WARNER ROBINS AIR LOGISTICS CENTER

# **DIGITAL RADIOGRAPHY & APPLICATIONS For AIRCRAFT MAINTENANCE**

**8 November**





# Overview



WARNER ROBINS AIR LOGISTICS CENTER

- Current State of Program/Project/Issue
- Program Requirements Roadmap
- Program Challenges/Opportunities
- Area/Issues Needing Improvement or Assistance
- Project or issue requirements & funding profile
- Government focal points
- Summary



# *Current State of Program/Project/Issue*



WARNER ROBINS AIR LOGISTICS CENTER

- **X-Ray Capture Technology currently consists of chemically processed film, computed radiography, digital radiography, and real time digital radiography.**
- **X-Ray source technology has evolved over time too, with variable focus, stable output, and pulse technology options now available.**
- **The state of X-Ray technology approved for each SPO varies and is an integral part of any plan to standardize equipment.**
- **Standardizing equipment and leaning our processes are the goals of this project.**



# WARNER ROBINS AIR LOGISTICS CENTER

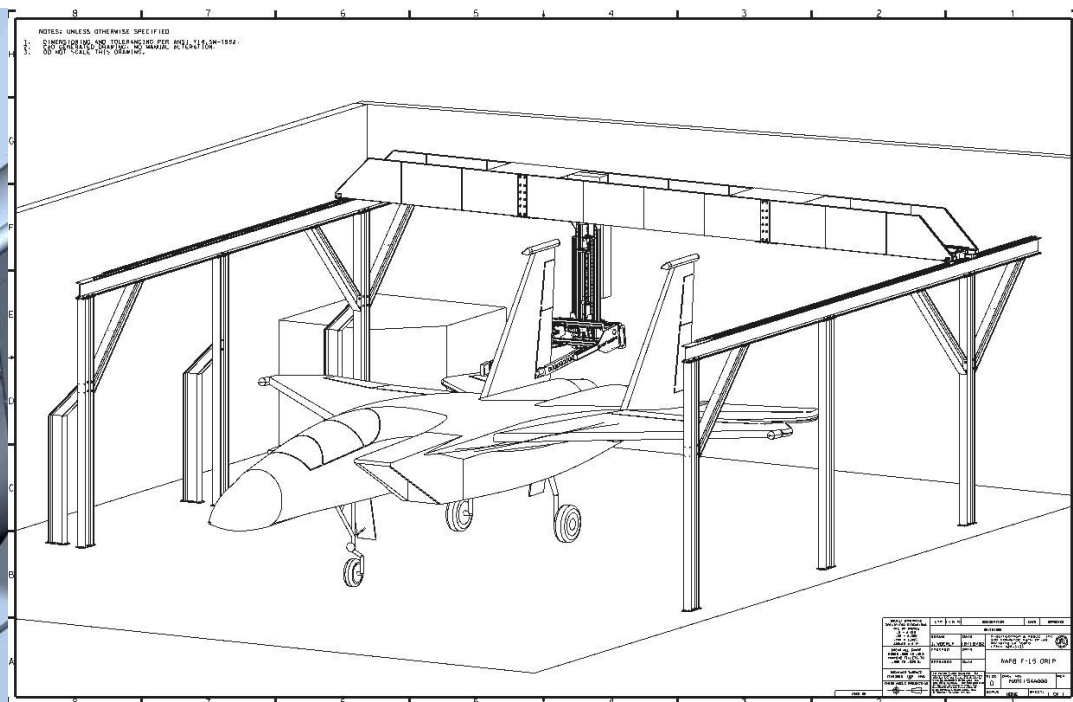
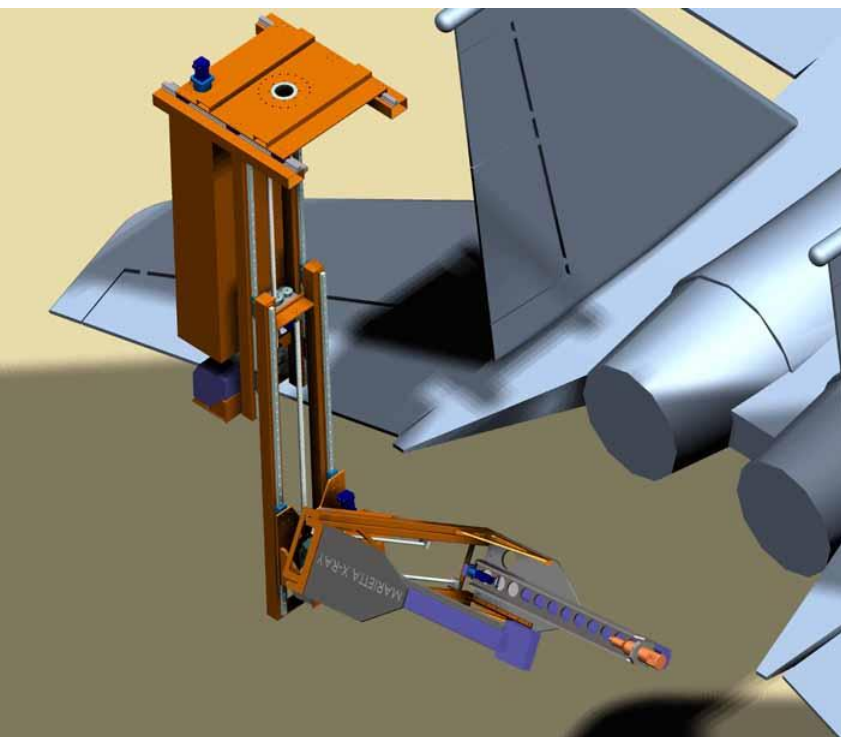



# *Program Requirements Roadmap*



WARNER ROBINS AIR LOGISTICS CENTER

	FY06	FY07	FY08
Rqmts	3 CR	4 CR	7 XRS
Funded			
Unfunded	\$300K	\$400K	\$350K



# *Program*

## *Challenges/Opportunities*



WARNER ROBINS AIR LOGISTICS CENTER

- Existing film process requires chemical processing of the film and the quality of the images varies from shot to shot.
- The NDI crew spends as much time going back and forth between the office, equipment storage location, and the job site as they do taking the shots, developing the film, and inspecting the shots.
- Operations and equipment are not standardized across aircraft systems. Complicates assigning work to X-Ray technicians.
- The film development process requires a significant amount of climate controlled storage space for the new and used film.



# Program

## Challenges/Opportunities cont.



WARNER ROBINS AIR LOGISTICS CENTER

- Existing process requires the use of large quantities of film fixer and developer chemicals, millions of gallons of rinse water per year (which has to be sent to and treated at the industrial waste plant), and the requirement to use a silver recovery system to extract the silver from the rinse water.
- Existing process is slow maximizing the amount of X-Ray's released and the time to take the shots. It is also a three step process which adds time too (CR is a two step and DR is a one step).



# *Area/Issues Needing Improvement or Assistance*



WARNER ROBINS AIR LOGISTICS CENTER

**The existing chemical film development process is slow, expensive, generates waste products, and needs to be replaced with a more modern alternative. There are some shots that require film (areas in the C-5 where the film is cut and pressed into non-flat shapes).**

**Computed Radiography seems to be the best fit for being our new standard process. The process of taking the shots is the same as film (except for far shorter exposure times), The plates are scanned into digital format, the images can be enhanced using software, and the storage issues are eliminated. I believe the process is as good for finding cracks as is the film process but the case will have to be made and sold to the SPO's. Some SPO's have approved this process for FOD and disk bonding, the others will have to update their T.O.'s.**



# *Area/Issues Needing Improvement or Assistance cont.*



WARNER ROBINS AIR LOGISTICS CENTER

**Digital Radiography takes us to a one step process but the drawback is the weight of the capture plate and it's high cost. Damaging a \$500 CR plate is bad enough, damaging a \$50K DR capture plate is an unacceptable risk for the maintenance environment we work in. This process requires a robotic positioning system to be a viable option. Like the CR process some SPO's have updated their T.O.'s and some have not.**

**Real Time Digital X-Ray is DR with pictures being taken at a rate of greater than 30 shots per second. Great potential for finding cracks but requires a robot positioning system and the real time process is only applicable for moderate metal thickness shots.**



# *Program or Issue Requirements & Funding Profile*



WARNER ROBINS AIR LOGISTICS CENTER

**Per a LEAN event on our NDI process it was decided to keep the real time F-15 X-Ray system in Bldg 144, keep a downscaled film capability (for the unique C-5 shots), and go to CR systems for the bulk of our work.**

**The equipment plan is to purchase 3ea CR systems in 06, 4ea more in 07, and start replacing our X-Ray source units in 08.**

**The SPO's will have to be included (to update the T.O.'s) and the issues around detecting cracks will have to be worked out.**

**Upgrading Source units is a follow on project. Funding sources will depend on per unit costs.**



# *Government Focal Points*



WARNER ROBINS AIR LOGISTICS CENTER

## **AIRCRAFT MAINTENANCE X-RAY PROGRAM**

**NDI Manager: Gary Collins /  
MXAOSN / 926-3853**

**Facility Engineer: Carlos Ortiz / MXAOPF /  
922-2950**

**Project Engineer: Lester N. Tennant / MXAOPF  
/ 922-2949**



# Summary



WARNER ROBINS AIR LOGISTICS CENTER

- We did a LEAN event to identify problems, requirements, and limiting factors.
- Distributed CR systems turned out to be the best way to cut costs and improve efficiency.
- We are going to keep a limited film capability and our real time system in Bldg 144.
- We are going to work with the SPO's to standardize our equipment and processes.
- We are going to address X-Ray source options next and then look for DR solutions.